

WindPro WindPro® LITE | WindPro® LITE



SwingPro® Lite is heavy and robust waterbase pavement sign for outdoor. It consists of 2 main articles: frame and the base. No sharp edges and has steel springs for flexibility. Poster use is double sided. Recommended to use film posters.

SwingPro® Lite ist ein schweres und robustes Strasseaufsteller für den Aussenbereich. Es besteht aus 2 Hauptartikeln: Rahmen und Wassertank. Es hat keine scharfen Kanten und die Stahlfedern sorgen für Flexibilität. Doppelseitiger Einsatz.

Base standard in dark grey color or black. Other colors are available upon request. Ground wheels in upside position enable easy movement of the product. Wassertank standardmässig in dunkelgrau. Andere Farboptionen bitte anfragen. Durch integrierte Rollen an der Unterseite leicht zu transportieren.

Please note that if the frame of SwingPro Lite and WindPro Lite is required with a "HEADER" option, then the standard articles cannot be used, please contact our sales department for the articles with a header option. Bitte beachten Sie, dass wenn der SwingPro Lite oder WindPro Lite mit Topschild erwünscht ist, unsere Standardartikel nicht eingesetzt werden können. Bitte wenden Sie sich dies bezüglich an Ihren Ansprechpartner in unserer Firma, um näheres über die Topschild Optionen dieses Artikels zu erfahren.

This product is not waterproof, but suitable to use outdoor. Dieses Produkt ist nicht wasserfest, aber geeignet für den Aussengebrauch.

Assembly in 60 seconds. Montiert in 60 Sekunden.

Color options / Farboptionen



Silver
Silber

Black
Schwarz



One top goes with 2 different bases.

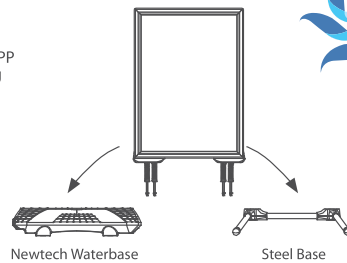

UYUP480945
Optional carry tool.

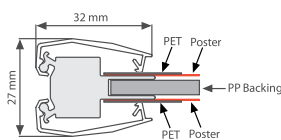

Sehr standfest

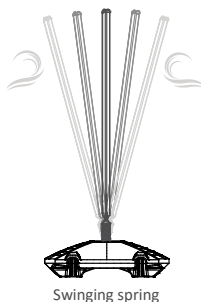
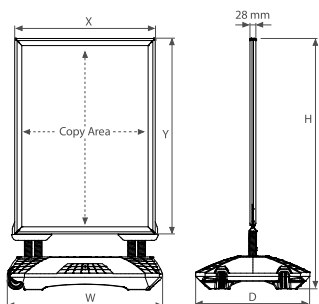

NEUTECH WATERBASE : HDLPE							WEIGHT	PACKING SIZE
SILVER	BLACK	SIZE	FOR	H	W	D	WITH PACKING	*W X H X D
UTWM003000	UTWM003010	720 X 530 mm	22" X 28"	999 mm	720 mm	530 mm	4,480 kg	555 X 750 X 178 mm
			24" X 36"	1203 mm	720 mm	530 mm		
			A1	1129 mm	720 mm	530 mm		
			B2	988 mm	720 mm	530 mm		
UTWM004000	UTWM04010	900 X 630 mm	28" X 44"	1405 mm	900 mm	630 mm	6,850 kg	605 X 930 X 178 mm
			30" X 40"	1304 mm	900 mm	630 mm		
			B1	1288 mm	900 mm	630 mm		
			A0	1477 mm	900 mm	630 mm		

FRAME : Silver anodised aluminium						WEIGHT	PACKING SIZE
SILVER	BLACK	EXTERNAL (x-y)	POSTER	COPY		WITH PACKING	*W X H X D
USWPLO0NA1	USWPLO0BA1	632 X 879 mm	594 X 841 mm	568 X 815 mm		6,385 kg	680 X 1140 X 35 mm
USWPLO0NA0	USWPLO0BA0	879 X 1227 mm	841 X 1189 mm	815 X 1163 mm		9,000 kg	925 X 1490 X 35 mm
USWPLO0NB1	USWPLO0BB1	738 X 1038 mm	700 X 1000 mm	674 X 974 mm		8,115 kg	785 X 1300 X 35 mm
USWPLO0NB2	USWPLO0BB2	538 X 738 mm	500 X 700 mm	474 X 674 mm		5,050 kg	585 X 1000 X 35 mm
USWPLO0N22	USWPLO0B22	597 X 749 mm	559 X 711 mm	533 X 685 mm		5,450 kg	645 X 1010 X 35 mm
USWPLO0N24	USWPLO0B24	648 X 953 mm	610 X 915 mm	584 X 889 mm		6,540 kg	690 X 1215 X 35 mm
USWPLO0N34	USWPLO0B34	800 X 1054 mm	762 X 1016 mm	736 X 990 mm		8,500 kg	845 X 1315 X 35 mm
USWPLO0N84	USWPLO0B84	749 X 1155 mm	711 X 1117 mm	685 X 1091 mm		9,000 kg	795 X 1415 X 35 mm

* Technische Änderungen vorbehalten!
* Technical changes reserved!

*W:Width H:Height D:Depth

