

WindPro LED



The innovative WindPro LED has a modern design and is a real eyecatcher! The mode of the WindPro LED can be switched from “energy-saving” in the night to “bright” during the day. A powerful LiFePO4 battery is hidden and locked in the base. A digital display indicates the status of the battery. The decorative cover-frame with black passepartout is made of polycarbonate. Moreover, the WindPro LED is lockable and the poster is fixed with clamps.



Patent No: OHIM DM/084 128

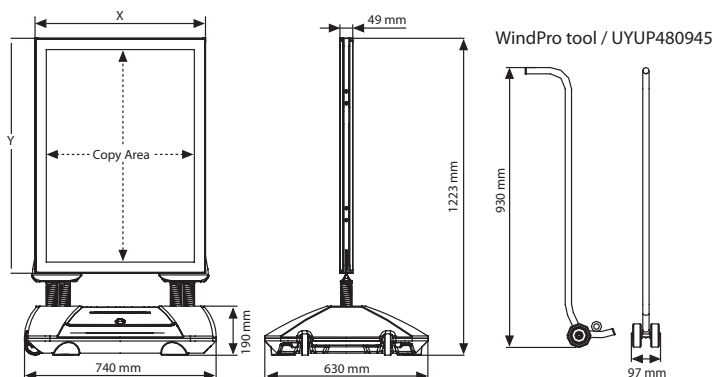

MATERIAL : Silver & black powder coated frame & waterbase				WEIGHT	PACKING SIZE
ARTICLE	EXTERNAL (x-y)	POSTER	COPY	WITH PACKING	*W X H X D
USWLO00NA1	658 X 907 mm	594 X 841 mm	572 X 821 mm	35,100 kg	840 X 1420 X 112 mm 680 X 780 X 198 mm

*W:Width H: Height D: Depth

